

Abstract

Demo - Motion Imitation for Robot HOAP3

Motion imitation is suggested to be a promising way to attend the problem of movement generation for robots. That attends two aspects. On the one hand, to reduce the immense search space. On the other hand, movements should become more human like.

However, this talk summarizes the steps to transfer a captured movement of a human to the robot HOAP3.

The movement is a "reaching out for grasping at" movement which is parameterized by the position grasped at. This exemplar movement is used to get a nice online demo, and is used in this manner to allow the robot to relocate objects on a table. The demo includes some rule learning, and takes place as follows: an advisor shows the robot, how to displace some objects for cleaning up the table. Afterwards, the robot has to clean up the objects as told by advisor.

Motion Imitation and Recognition using Parametric Hidden Markov Models

Dennis Herzog, Volker Küger, Aleš Ude*

Aalborg University, Copenhagen

*Jožef Stefan Institute, Slovenia

Motivation

- Important role: recognition and synthesis of human motions for interaction between human and humanoid
 - Humanoid needs to recognize human movement
 - to understand what human is doing
 - Humanoid can learn from people how to move
 - and this in a humanlike way
- Parametric Hidden Markov Model is a comprising way for at least some parametric movements
- HMM framework includes: training, synthesis, and recognition

Imitation of Moves

Teacher

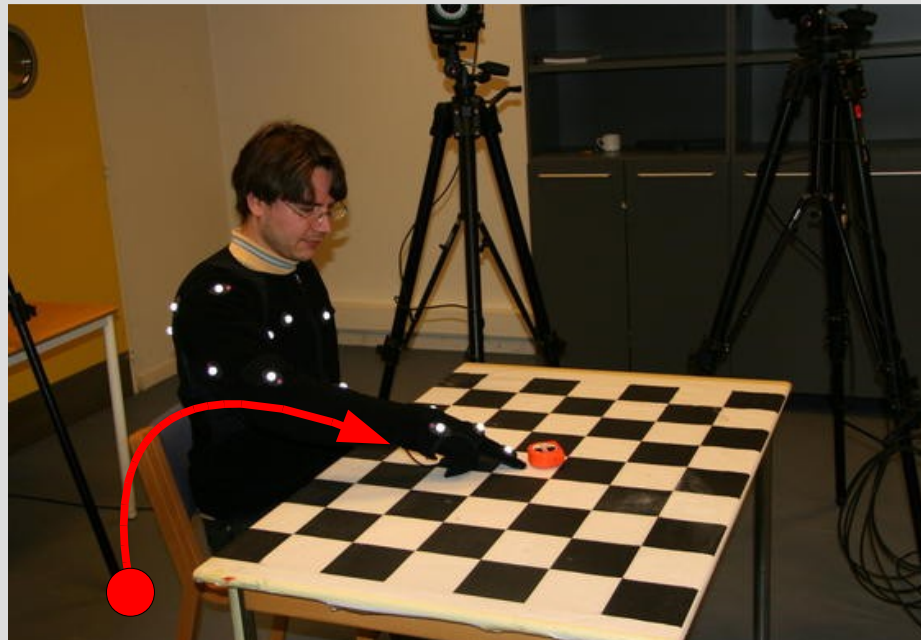

person

Robot

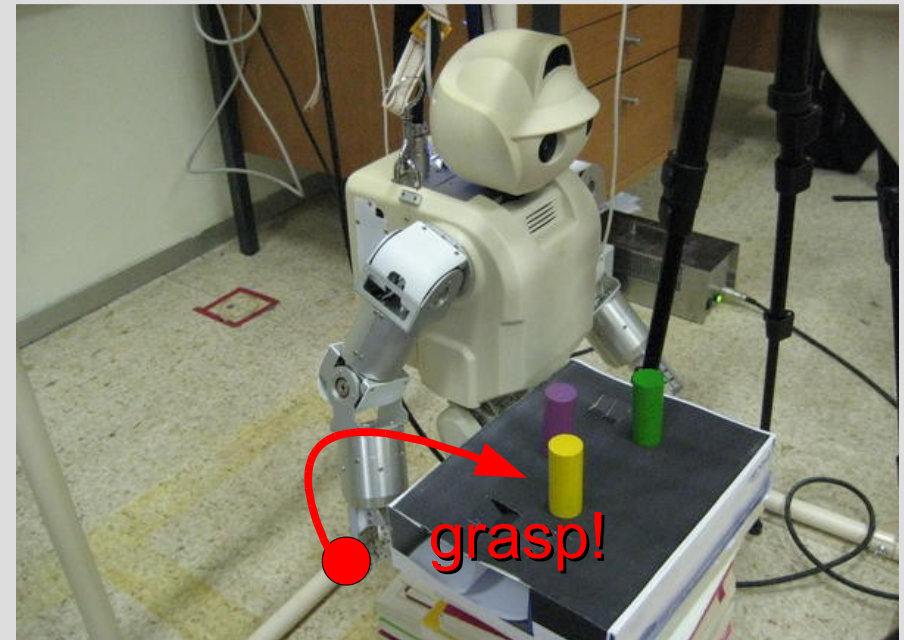

HOAP-3

Outline

1. Capturing of Movements
2. Towards Parametric HMMs
 - Motion Synthesis
 - HMM, Parametric HMM
 - Training, Synthesis & Recognition
3. Robot Demo
 - Motion Transfer to Robot HOAP3
 - Relocating Objects on a Table
 - Rule-learning Robot Demo / Video
4. Recognition Demo / Video

Capturing Movements

Capturing Movements

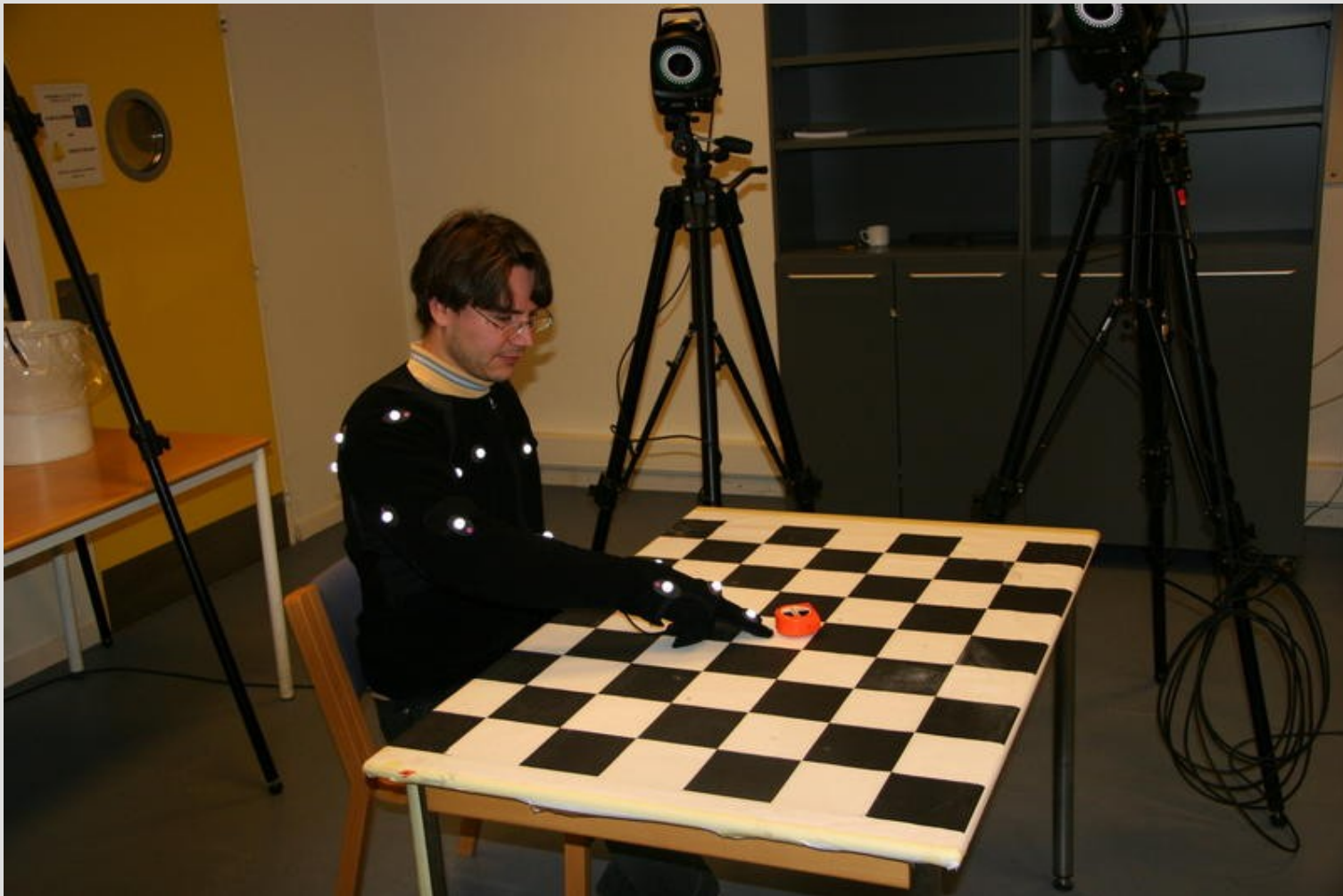

Capturing Movements

Vicon System

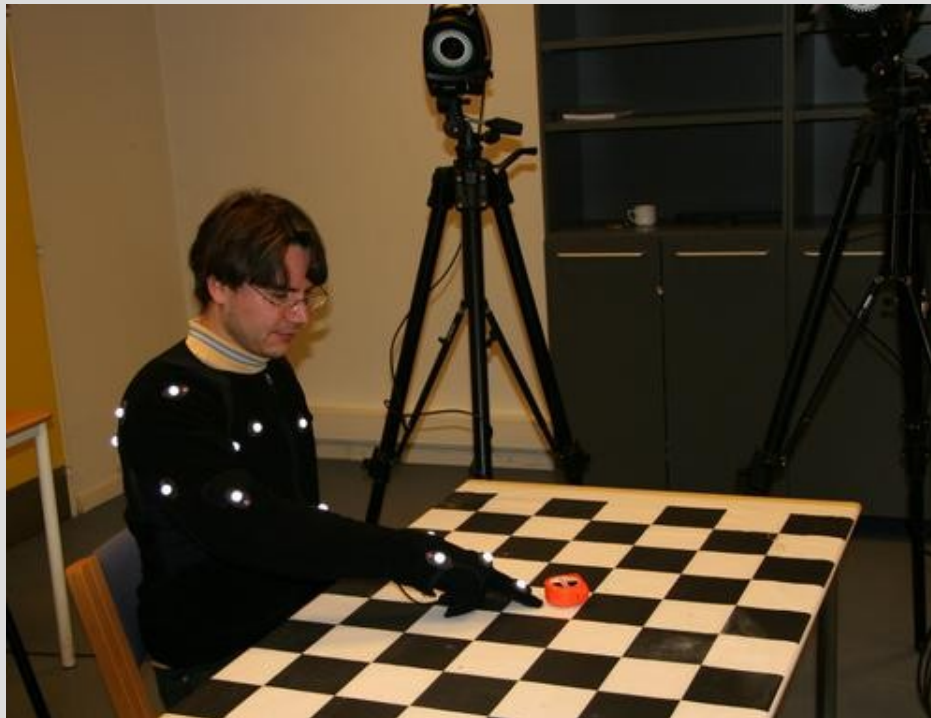

1. 8 cameras @120Hz+, sync
 - infrared sensitive
 - infrared emitter
2. high reflective markers
3. Capturing
 - generate 3d markers
 - estimate model pose

Capturing Movements

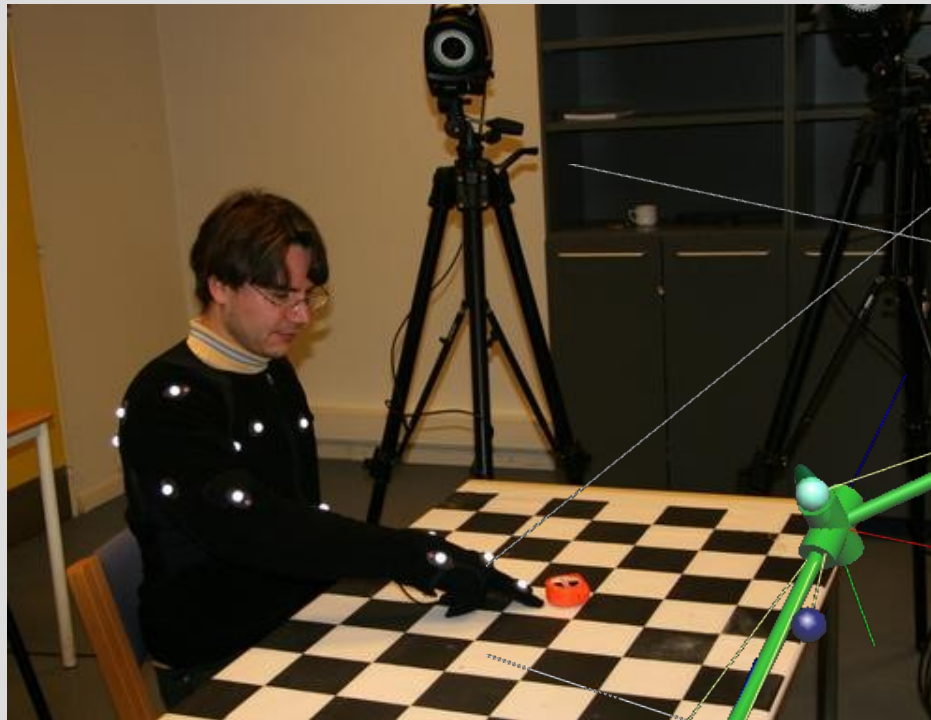

Vicon Model of Left Arm

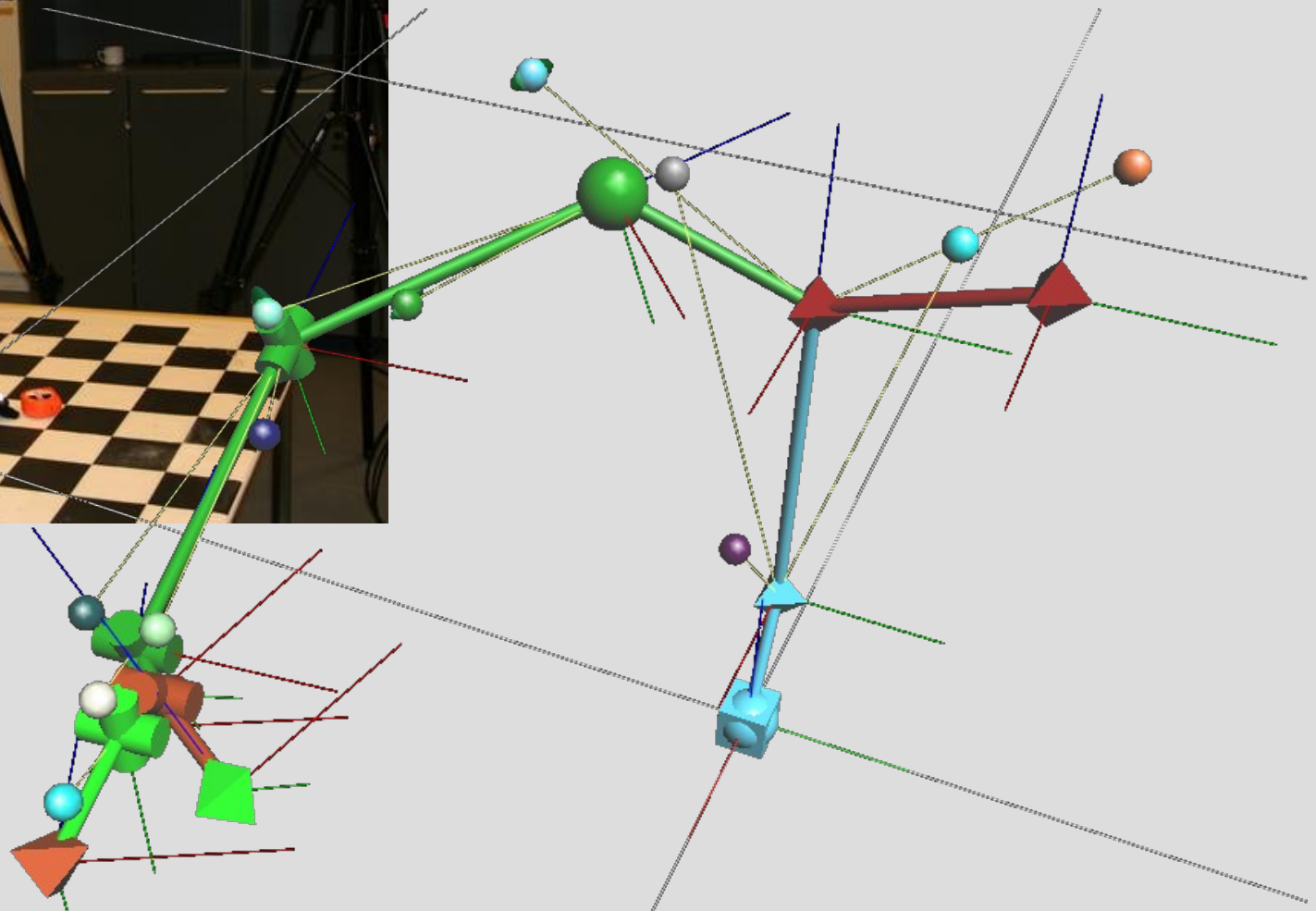

Capturing Movements

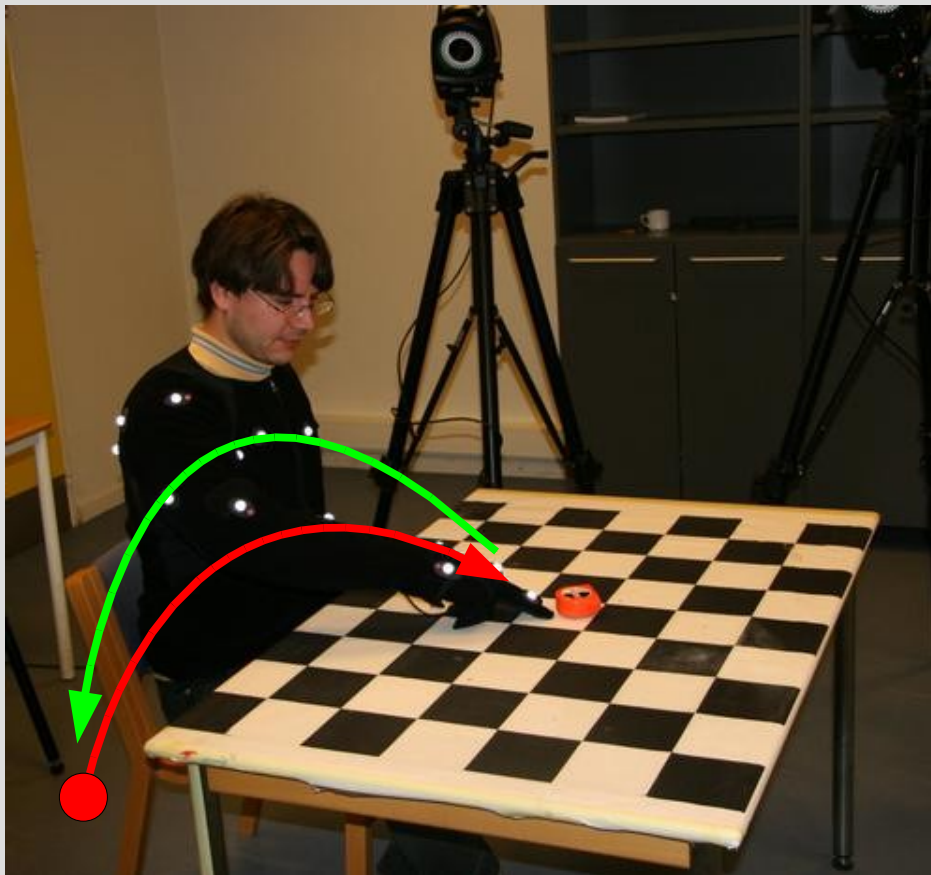

Movements for certain Positions

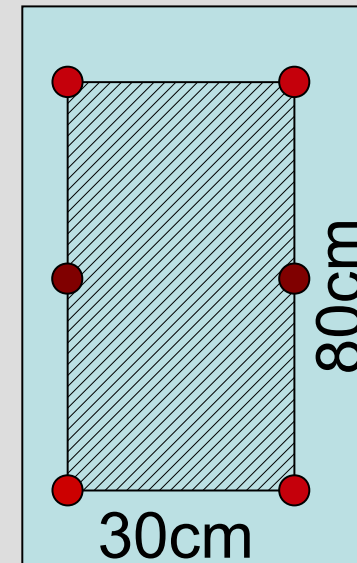

1. at least for 4 corners
2. with few repetitions each
 - for averaging

Parametric HMM

Motion Synthesis

Motion Synthesis

Motion Synthesis by Interpolation

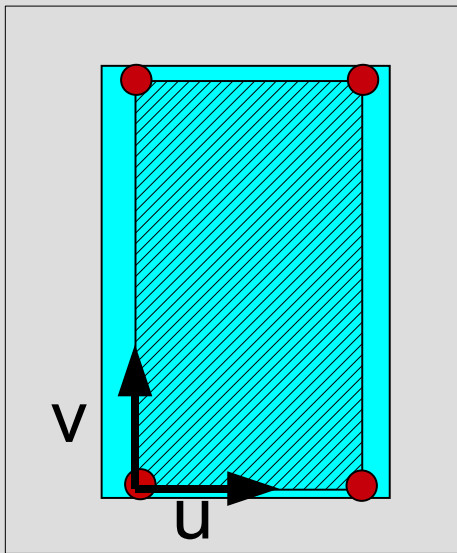
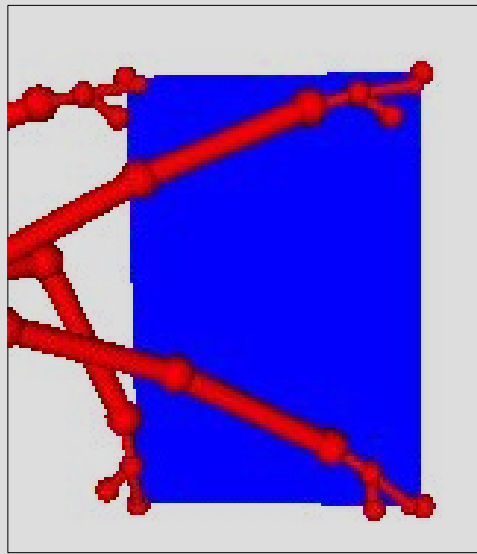
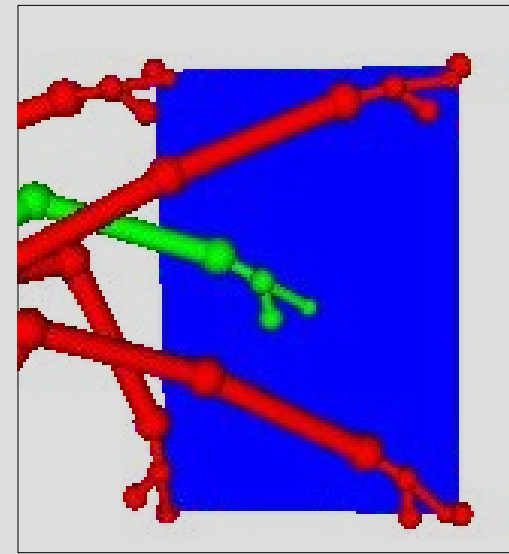

table plane



4 arm states



mean

Motion Synthesis

Interpolation requires Warping wrt. Dynamics

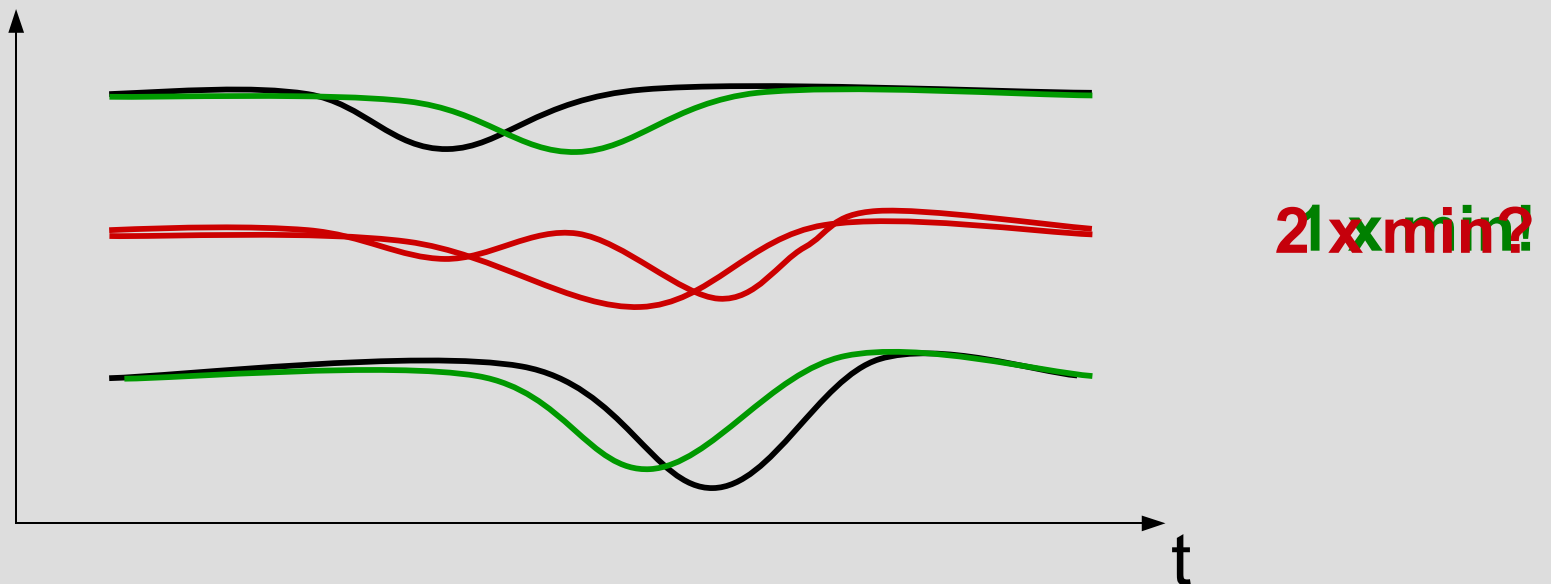

Hidden Markov Model

HMM

- **Hidden Markov Model (HMM)** is a
 - State Machine, extended in probabilistic way

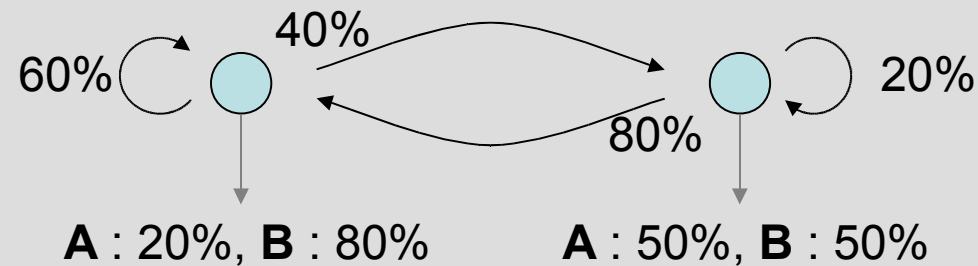

- Continuous left-right HMM: model time series

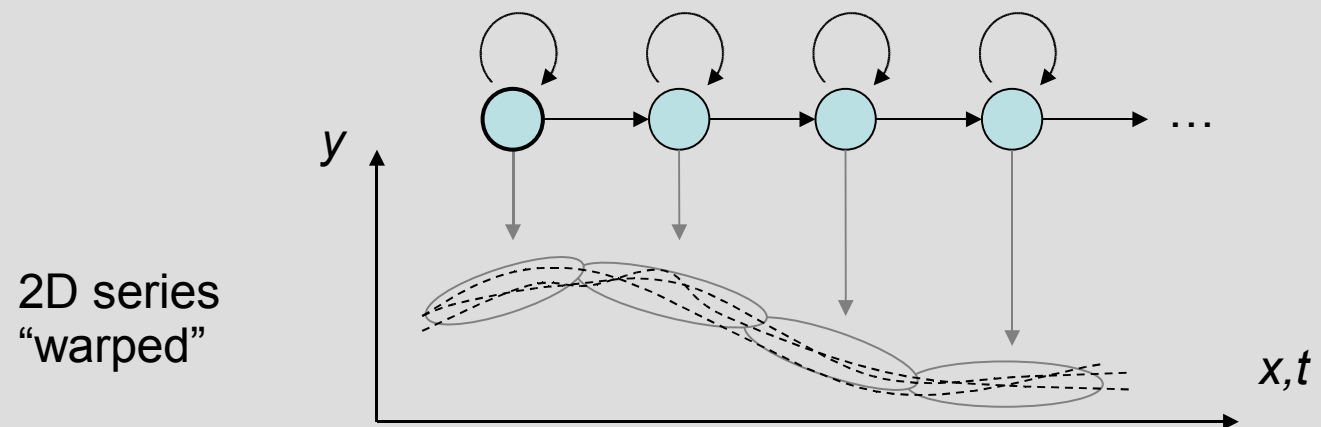

HMM

- HMM λ – Basic Problems

- Training of Model Parameters

- Baum/Welch EM Algorithm (ML estimate)

" $P(X | \lambda) \rightarrow \max, \lambda$ "

- Evaluation Problem (**Recognition**)

- Forward/Backward Algorithm

"eval $P(\mathbf{x} | \lambda)$ "

(Synthesis, here, straight forward for a left/right model)

Parametric HMM

Parametric HMM: a movements with single parameter

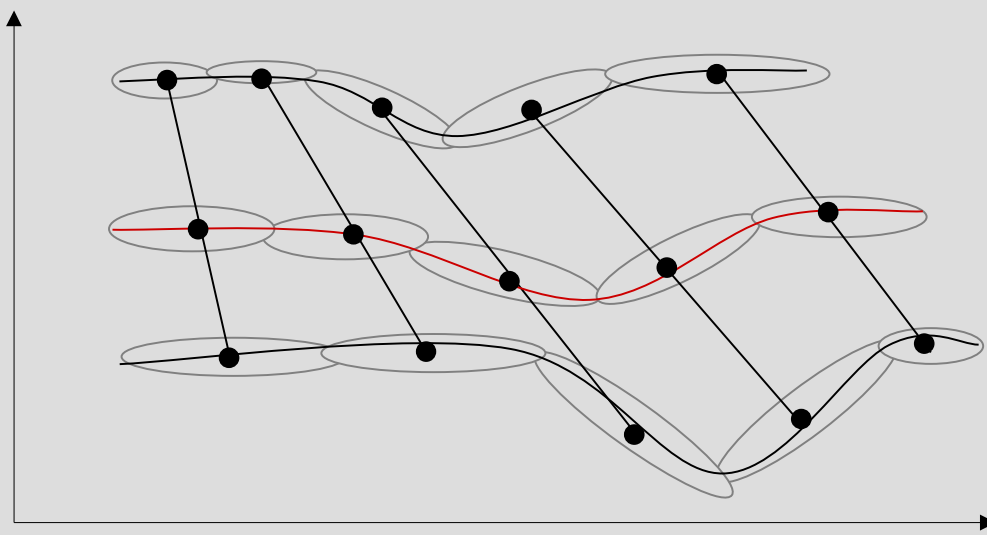

$$\lambda^{\phi=0}$$

$$\lambda^{\phi=1/2} = (\lambda^{\phi=0} + \lambda^{\phi=1}) / 2$$

$$\lambda^{\phi=1}$$

align HMM states →

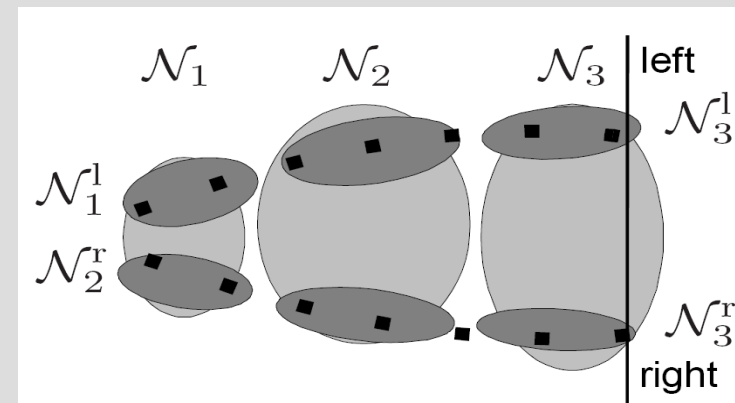

HMM – Alignment

Aligned HMM States (Interpolated Synthesis)

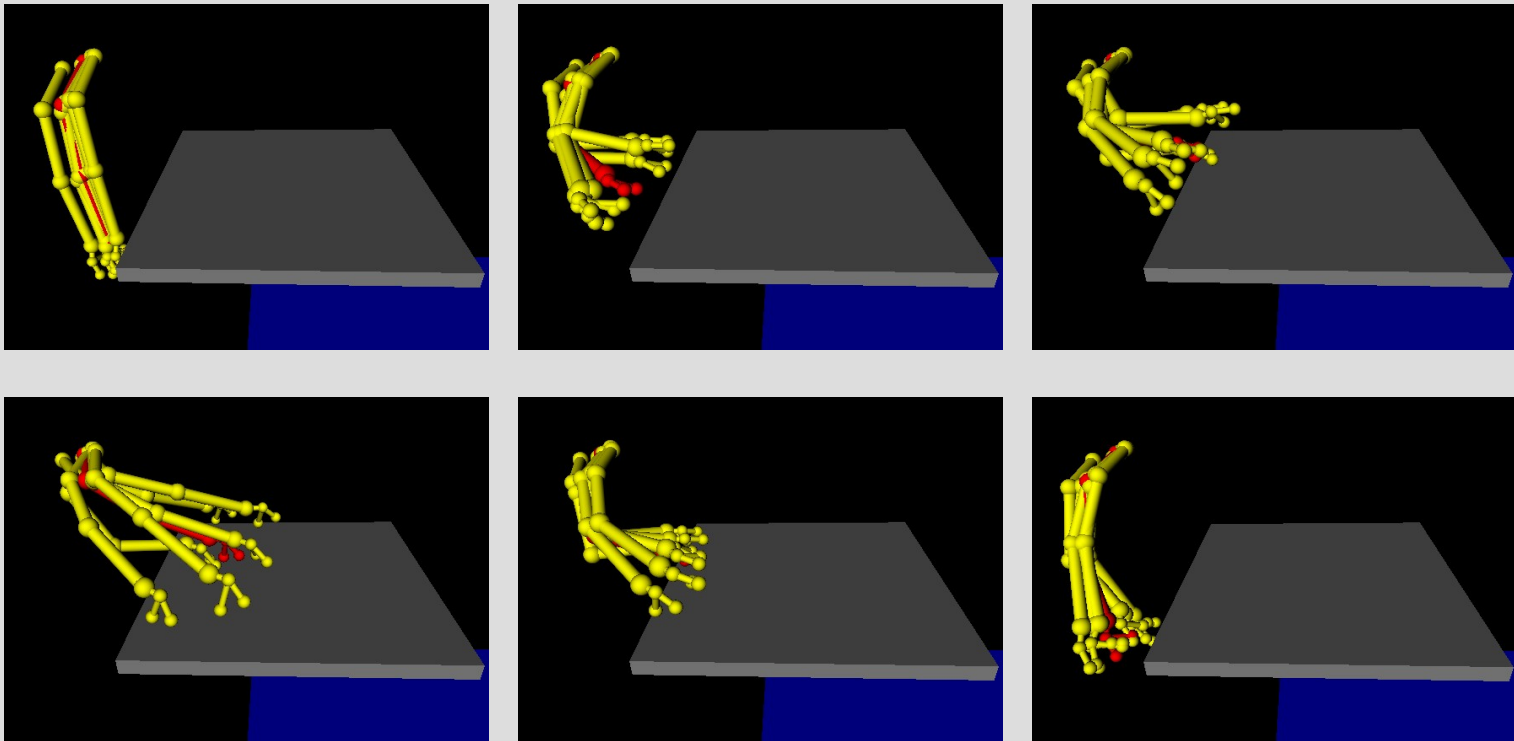

HMM - Recognition

Recognition

Given: movement \mathbf{x} ,

models λ_k^{uv} for each types k of move

- Estimate most likely parameters u, v for each k

$$(u, v)_k = \arg \max_{u, v} P(\mathbf{x} / \lambda_k^{uv})$$

- Recognition:

- classify as class k of highest likelihood
 - » or thresholding, in case of one motion class

- movement parameters are given by $(u, v)_k$

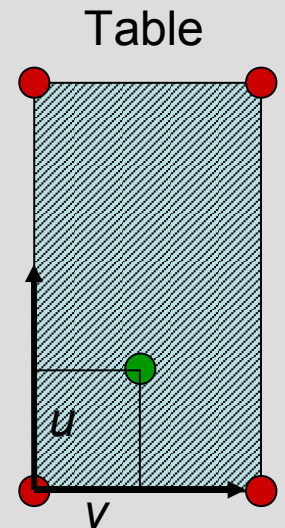

Robot Demo

Motion Transfer to Robot

Entities used of the Humans Motions

1. Position of Elbow

- rescaled to robot's dims
- relative to shoulder

q

2. Position of End-Effector

- mean of: index-finger, thumb, knuckle

r

3. Orientation of Gripper

- vector: finger --> thumb

o

Motion Transfer to Robot

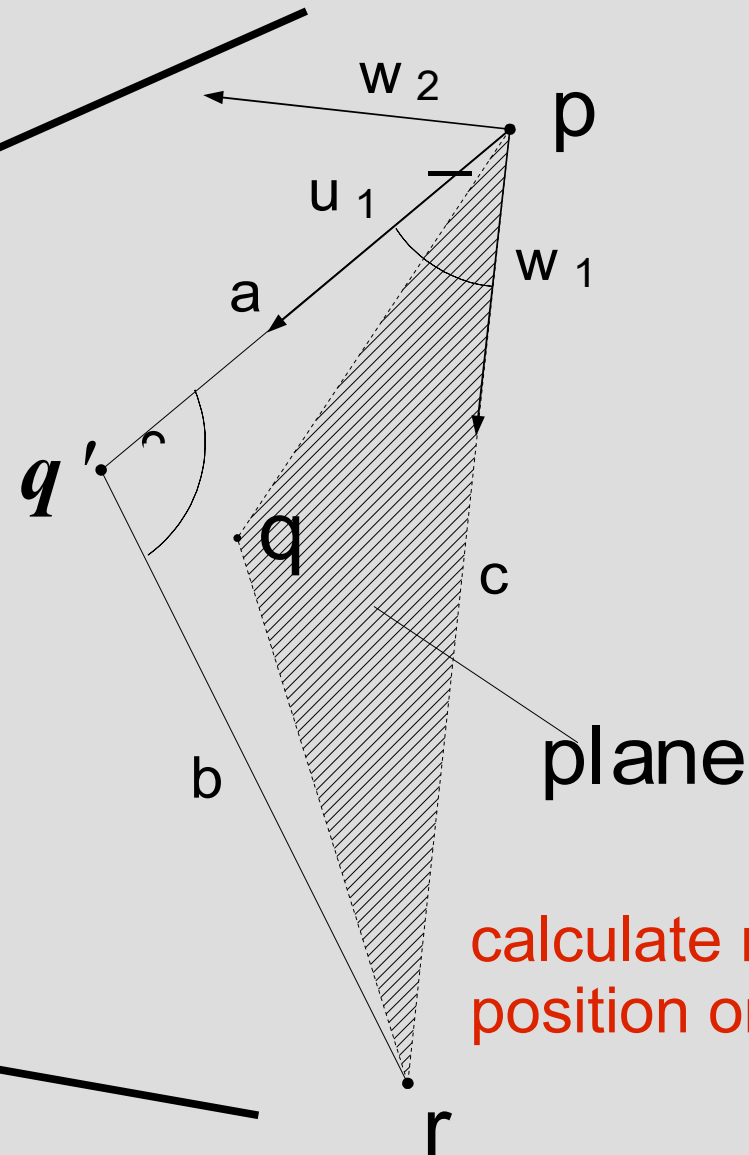
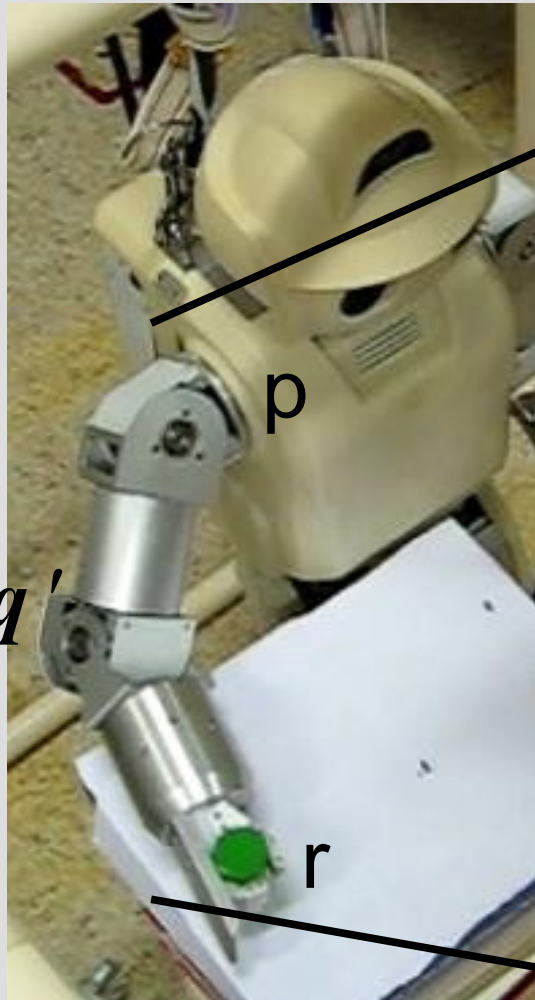

calculate robots elbow position on plane!!!!

Motion Transfer to Robot

1. Law of Cosines

Elbow

$$\gamma = \arccos \frac{a^2 + b^2 - c^2}{2ab}$$

Upper Arm

$$\beta = \arccos \frac{a^2 + c^2 - b^2}{2ac}$$

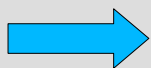

$$\mathbf{u}_1 = \cos \beta \mathbf{w}_1 + \sin \beta \mathbf{w}_2$$

(direction of upper arm)

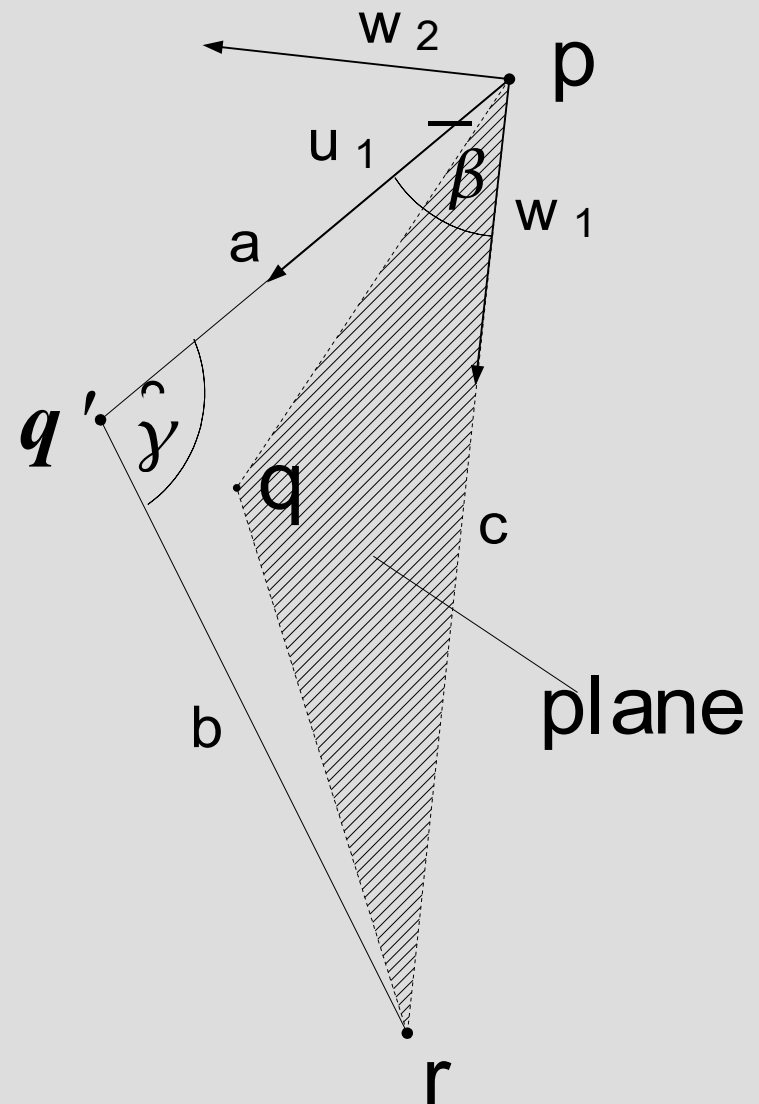

Motion Transfer to Robot

2. Cardan Angles of Shoulder (Euler formula)

$$\phi = \arctan2(r_{32}, r_{33})$$

$$\theta = -\arcsin(r_{31})$$

$$\psi = \arctan2(r_{21}, r_{11})$$

where

$$(r_{ij}) = [\mathbf{u}_1 \ \mathbf{u}_2 \ \mathbf{u}_3]^T [\mathbf{v}_1 \ \mathbf{v}_2 \ \mathbf{v}_3]$$

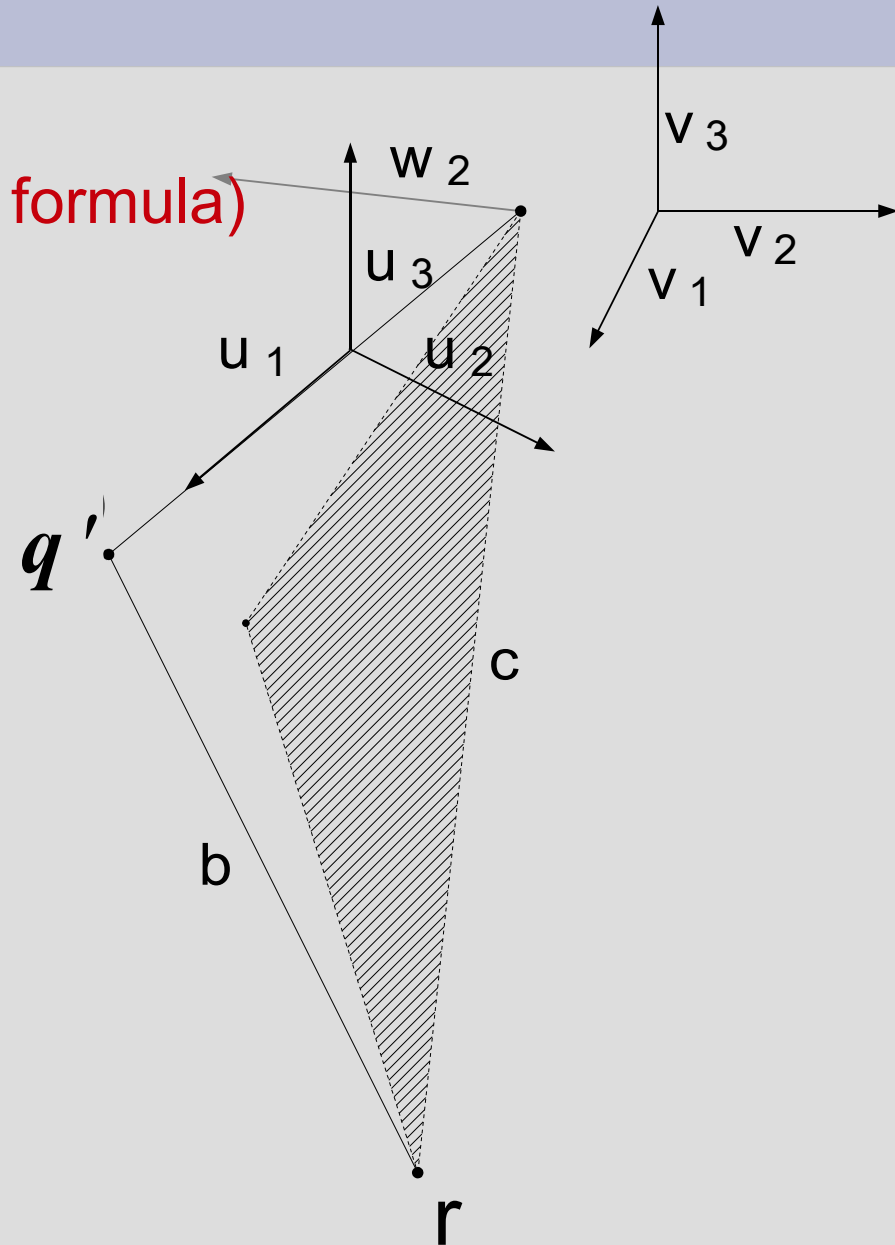

Motion Transfer to Robot

3. Orientation of Gripper

α given by projection \mathbf{o}' of the vector \mathbf{o} : finger-->thumb

twist plane of the robot's wrist

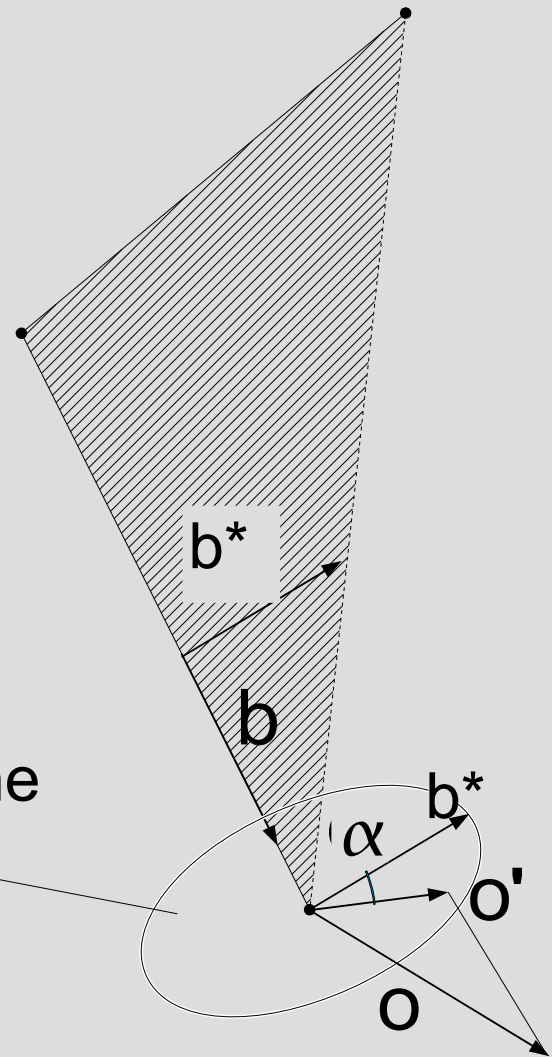

Relocating Movement

Relocating Movement

Movement Generation by Interpolation

1. use 4 additional movements s_t^{ij2} with grasped at positions t_{ij2} in upper plane --> each point t space reachable
2. - we can generate movements to arbitrary points
- if we freeze the time during playback while changing interpolation parameters we can move e.g. the gripper at table-top

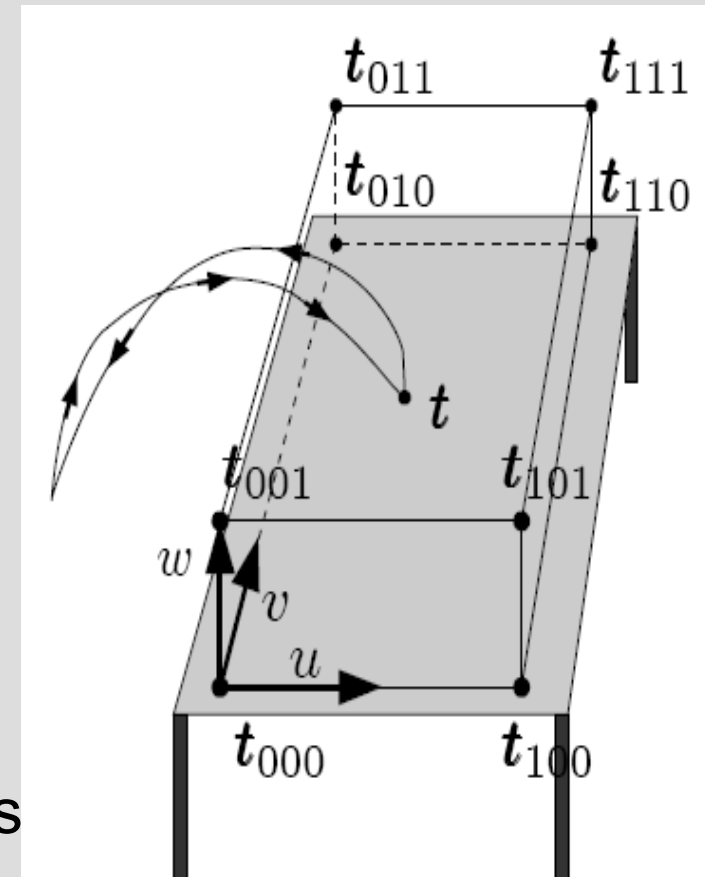

Relocating Movement

Placing Gripper before Object

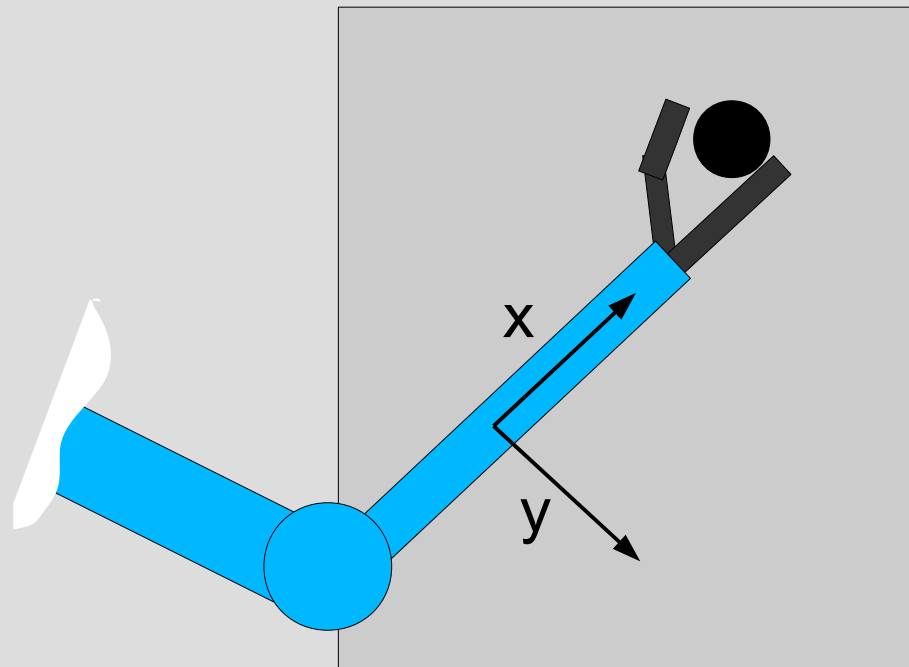

Relocating Movement

Relocating an Object

1. playback first part of movement reaching at a position before the object
2. align gripper to table-top & open gripper
3. move gripper to object (by changing u,v,w)
4. close gripper
5. lift object up (by changing w)
6. move to new position (by changing u,v)
7.

The Robot Demo

The Robot Demo

A Rule Learning Demo

1. Calibration

- Placing object at four corners
- learn homography between table-top and image plane

2. Learning of where to place the three objects

- by demonstration

3. Cleaning up the table

- order given by pointing at the objects

A Recognition Demo

A Recognition Demo

1. 3D body tracker
 - for determining shoulder, elbow, and wrist positions
2. Pointing movements are demonstrated (not shown!)
 - for training of the PHMM
3. Pointing movements, and pointed at positions are recognized
 - ...in order to advise an virtual robot arm

Concluding Remarks

Concluding Remarks

- We introduced an Parametric HMM Framework
 - Suitable to represent parametric movements of specific type
 - Training, recognition, and synthesis in one Framework
- A robot demo has shown
 - the synthesis/robot control works in a humanlike way
- A recognition demo has shown
 - movement type and parameters recognizable seems to be robust